

E1 ELEVATION

E2 ELEVATION

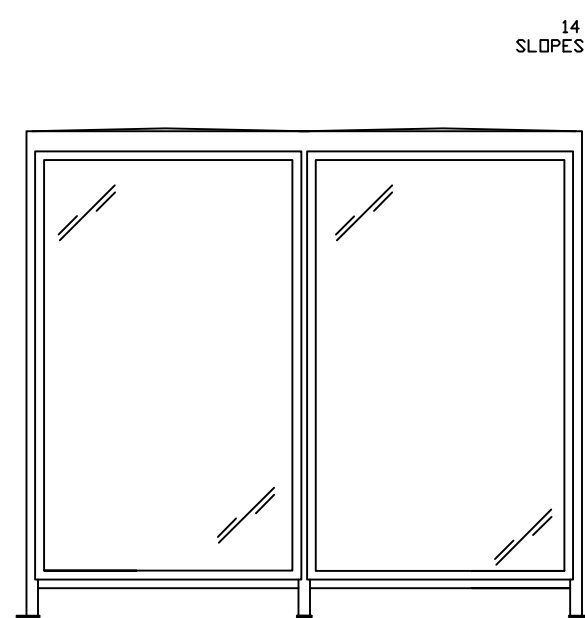

E3 ELEVATION

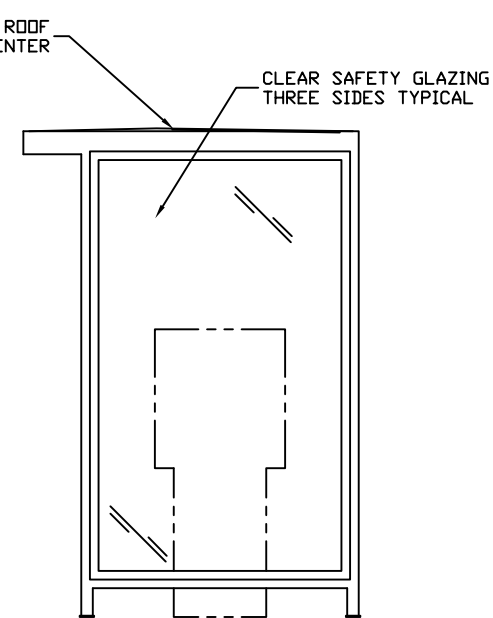

E4 ELEVATION

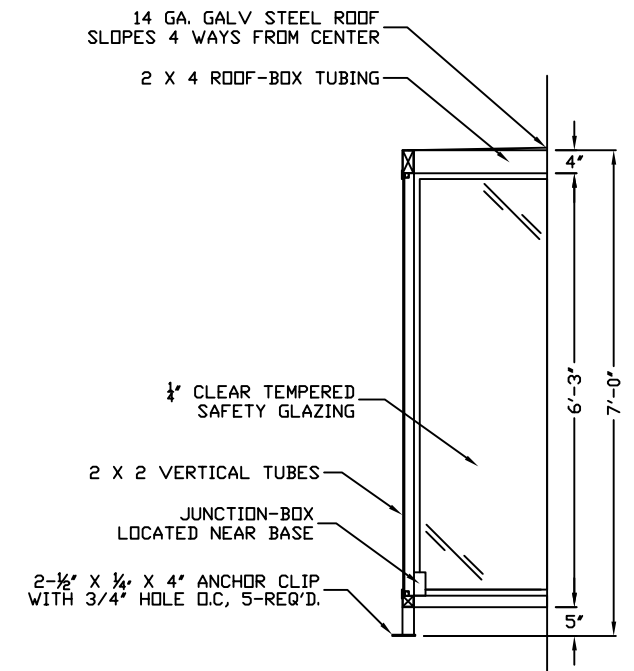

S1 SECTION

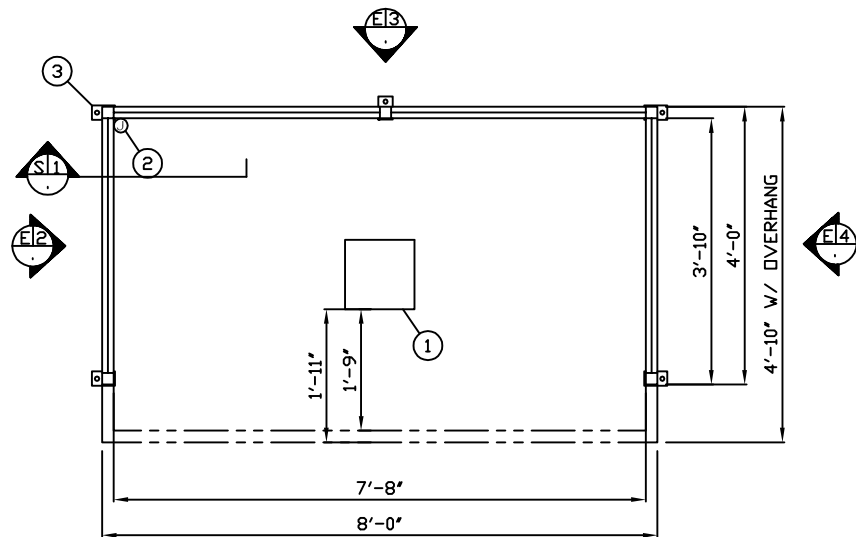

E1 PLAN VIEW

1. FLUORESCENT LIGHT W/PHOTOCELL MOUNTED ON ROOF TOP AND WIRING TO TERMINATE AT J-BOX #2.
2. SINGLE GANG WEATHER PROOF JUNCTION BOX LOCATED NEAR GRADE FOR LIGHT WIRE TERMINATION.
3. 2-1/2" X 1/4" X 4" ANCHOR PLATES WITH 3/8" DIAMETER ANCHOR BOLT HOLES, 5-REQ'D.

NOTE: PAR-KUT BOOTHS ARE OF SINGLE UNIT WELDED STEEL CONSTRUCTION, FACTORY ASSEMBLED AND DELIVERED SET UP. FAILURE TO SECURELY ANCHOR BOOTH MAY RESULT IN OVERTURNING OF UNIT AND SERIOUS INJURY TO OCCUPANT.

- A. CLEAR SAFETY GLAZING SET IN PAINTED STEEL EXTERIOR WINDOW FRAMES WITH REMOVABLE ANODIZED ALUMINUM INTERIOR WINDOW STOPS.
- B. PAINT - A RUST INHIBITING TWO PART INDUSTRIAL POLYURETHANE FINISH.
- C. ELECTRICAL - LIGHT WIRING TO J-BOX BY PAR-KUT.
- D. NO LIFTING RING(S) ARE PROVIDED ON ROOF.
- E. NO ON SITE WORK BY PAR-KUT.

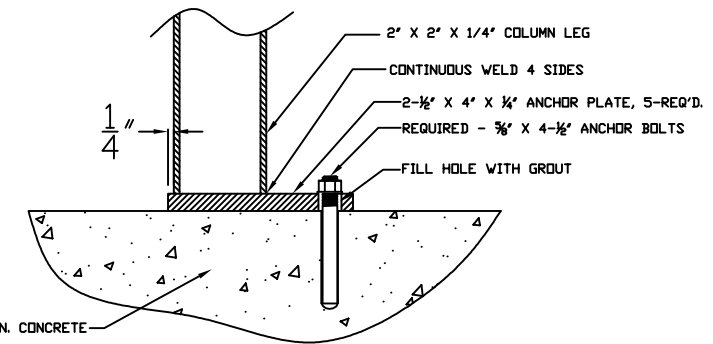

FIELD DRILLED ANCHOR BOLT DETAIL
NO SCALE

THIS DRAWING IS FOR REFERENCE PURPOSES ONLY. PAR-KUT BUILDINGS MUST BE SECURELY ANCHORED IN PLACE AND MUST BE PROPERLY GROUNDED. ADEQUATE SIZED ANCHOR BOLTS SHALL BE USED. THE SIZE AND DEPTH OF THE ANCHORS SHOULD BE OF SUFFICIENT DESIGN TO WITHSTAND THE HIGHEST RECORDED WIND SPEEDS IN THE AREA OF INSTALLATION. CONSULT A PROFESSIONAL ENGINEER FAMILIAR WITH THE WEATHER CONDITIONS IN THE AREA.

NOTE: THIS PRINT AND DESIGN ARE THE PROPERTY OF PAR-KUT INTERNATIONAL, INC. IT MUST NOT BE REPRODUCED IN ANY MANNER, NOR SHALL IT BE SUBMITTED TO OUTSIDE PARTIES FOR EXAMINATION WITHOUT OUR CONSENT. IT SHALL BE USED ONLY AS A MEANS OF REFERENCE TO WORK DESIGNED AND FURNISHED BY PAR-KUT. PAR-KUT RESERVES THE RIGHT TO MAKE CHANGES TO DESIGN FOR ENGINEERING PURPOSES WITHOUT NOTICE. REVISIONS MAY NOT BE NOTED.

PAR-KUT INTERNATIONAL, INC.
40961 Production Drive
Harrison Twp., Mich.
48045-1551
PH. (586) 468-2947
www.parkut.com



DWG# 11-165

GENERAL NOTES

PAINT COLOR: MATCH CUSTOMER SAMPLE

ESTIMATED WEIGHT: 700 LBS.

SCALE NTS	DRAWN BY JHS	REVISED 7-1-2011
DATE 4-25-2011	SIZE 4' X 8'	QTY 1
CHK'D BY:	SALES REPRESENTATIVE	