

E1 ELEVATION

E2 ELEVATION

E3 ELEVATION

E4 ELEVATION

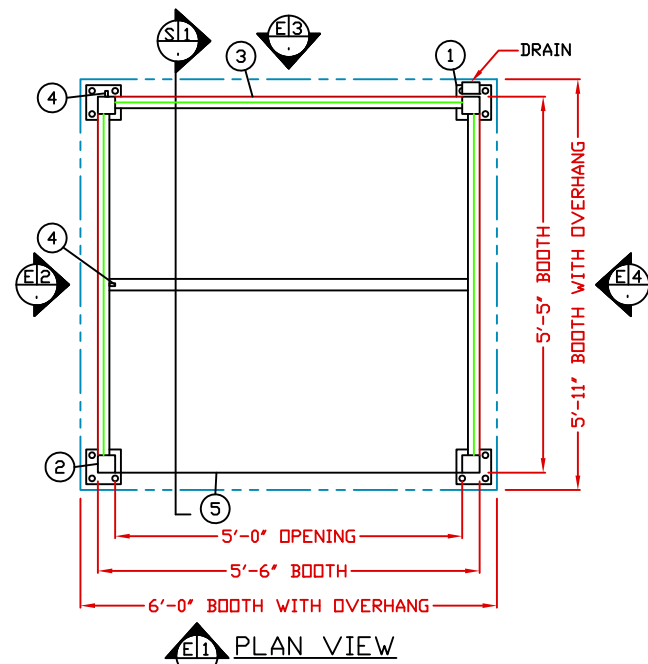

E1 PLAN VIEW

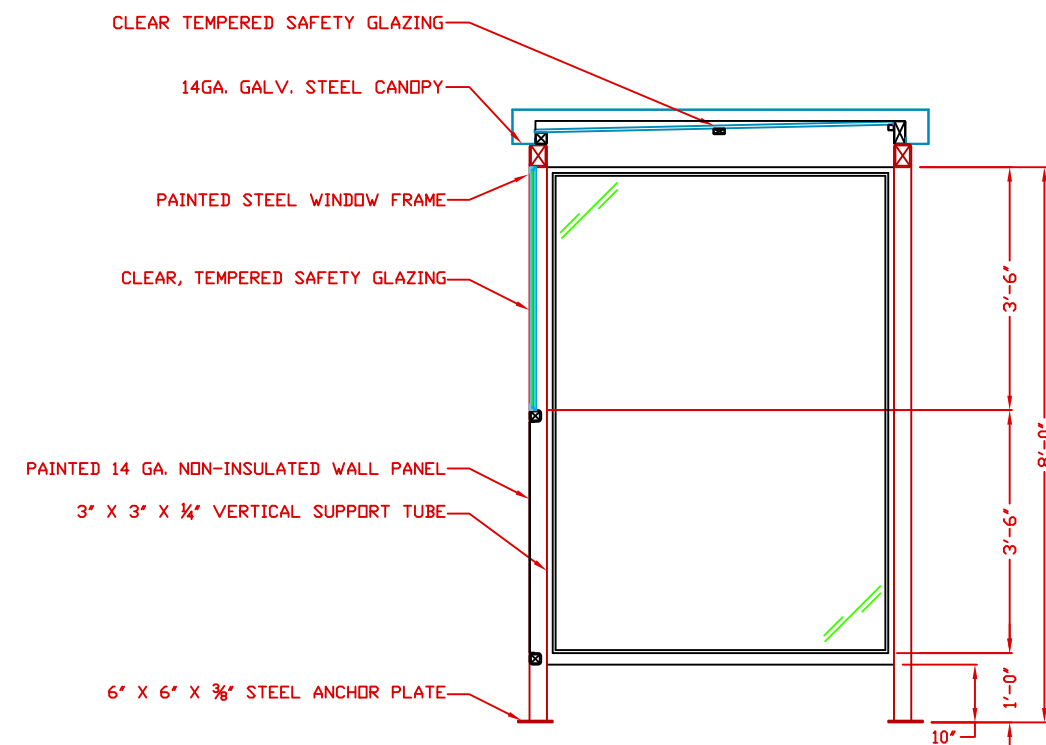

S1 SECTION
NO SCALE

1. 6" X 6" X 3/8" STEEL ANCHOR PLATE, 4-REQ'D, WITH 1" ANCHOR BOLT HOLES. ANCHOR SHELTER AFTER FINAL LOCATION. ANCHOR BOLTS NOT INCLUDED.
2. 3" X 3" X 1/4" STEEL VERTICAL SUPPORT TUBES, 4-REQ'D.
3. 14GA. GALV. PAINTED STEEL PANEL WITH 18GA. INTERIOR STEEL PANEL. NOT INSULATED.
4. 1/2" DIA. NIPPLE WITH CONDUIT TO 1/2" NIPPLE OUT E-3 SIDE FOR FUTURE CUSTOMER USE
5. CLEAR TEMPERED GLAZING FOR SKY LIGHT TO COVER THE ENTIRE ROOF.

NOTE: PAR-KUT SHELTER IS OF SINGLE UNIT WELDED STEEL CONSTRUCTION, FACTORY ASSEMBLED AND DELIVERED SET UP. FAILURE TO SECURELY ANCHOR SHELTER MAY RESULT IN OVERTURNING OF UNIT.

- A. GLAZING - CLEAR TEMPERED SAFETY GLAZING SET IN PAINTED STEEL WINDOW FRAMES. SKY LIGHT WILL BE CLEAR TEMPERED GLAZING SET ON STEEL TUBE FRAME.
- B. PAINT - FINISH SHALL BE SINGLE COLOR OF CHOICE, IMRON POLYURETHANE HIGH GLOSS INDUSTRIAL COATING. SHALL BE APPLIED TO ALL EXPOSED METAL SURFACES. THIS EXCLUDES FLOOR, ROOF SURFACE, ANODIZED ALUMINUM WINDOW FRAMES AND ANY STAINLESS STEEL COMPONENTS (IF USED).
- C. ELECTRICAL - ALL WIRING BY PAR-UT TO BE #12(MIN) STRANDED COPPER, THHN ENCLOSED IN 1/2"(MIN) E.M.T. PER NATIONAL ELECTRIC CODE. FITTINGS, FIXTURES, AND DEVICES ARE U.L. LABELED. ALL WIRING TO TERMINATE AT C.B. PANEL. ALL CIRCUITS HAVE GREEN GROUND WIRE.
- D. SHELTER WILL HAVE A 3" CANOPY OVERHANG ON ALL SIDES.
- E. LIFTING RING(S) ARE PROVIDED ON ROOF.
- F. NO ON SITE WORK BY PAR-KUT.

NOTE: THIS PRINT AND DESIGN ARE THE PROPERTY OF PAR-KUT INTERNATIONAL, INC. IT MUST NOT BE REPRODUCED IN ANY MANNER, NOR SHALL IT BE SUBMITTED TO OUTSIDE PARTIES FOR EXAMINATION WITHOUT OUR CONSENT. IT SHALL BE USED ONLY AS A MEANS OF REFERENCE TO WORK DESIGNED AND FURNISHED BY PAR-KUT. PAR-KUT RESERVES THE RIGHT TO MAKE CHANGES TO DESIGN FOR ENGINEERING PURPOSES WITHOUT NOTICE. REVISIONS MAY NOT BE NOTED.

PAR-KUT INTERNATIONAL, INC.
40961 Production Drive
Harrison Twp. Mich.
48045-1551
PH. (586) 468-2947
www.parkut.com



DWG# SHLT-014 SHEET A-1
PMC PAY MACHINE COVER

GENERAL NOTES

PAINT COLOR: _____		
PD#	SCALE	DRAWN BY
NTS	NSG	NSG
DATE	SIZE	REVISED
1-6-2011	5'-5" X 5'-6"	QTY
CHK'D BY:	SALES REPRESENTATIVE	