

TRAILER EQUIPPED WITH SAFETY CHAINS & RUNNING LIGHTS

NOTICE: MAXIMUM SAFE TOWING SPEED -- 25 MPH NOT DESIGNED FOR HIGHWAY USE!

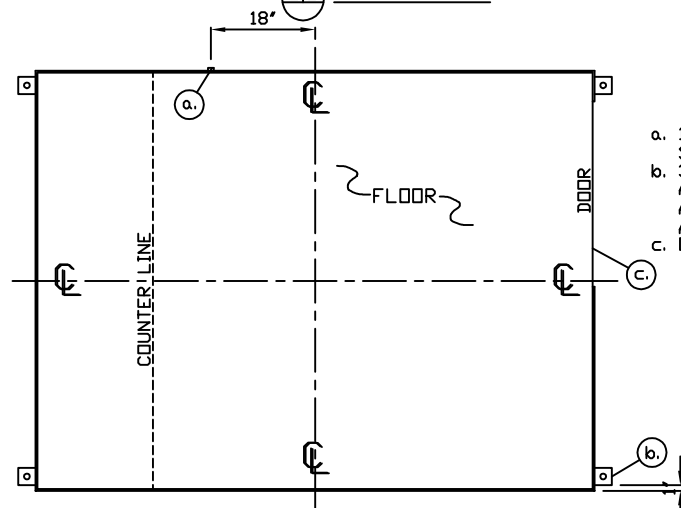

NOTE: PROVIDE 120/240V. 1Ø-3 WIRE SERVICE WITH GROUND. SERVICE ENTRANCE/ANCHOR BOLT LAYOUT

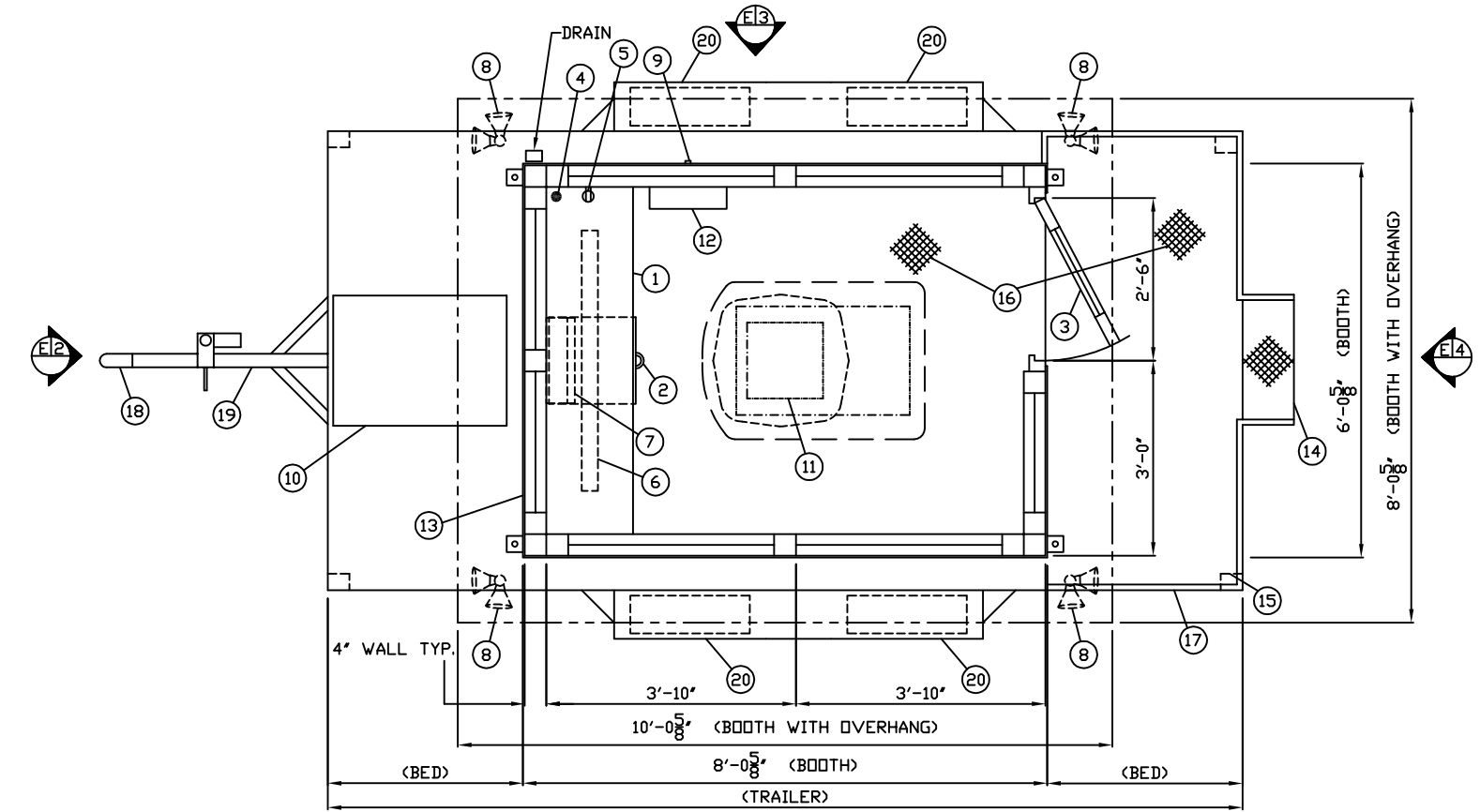
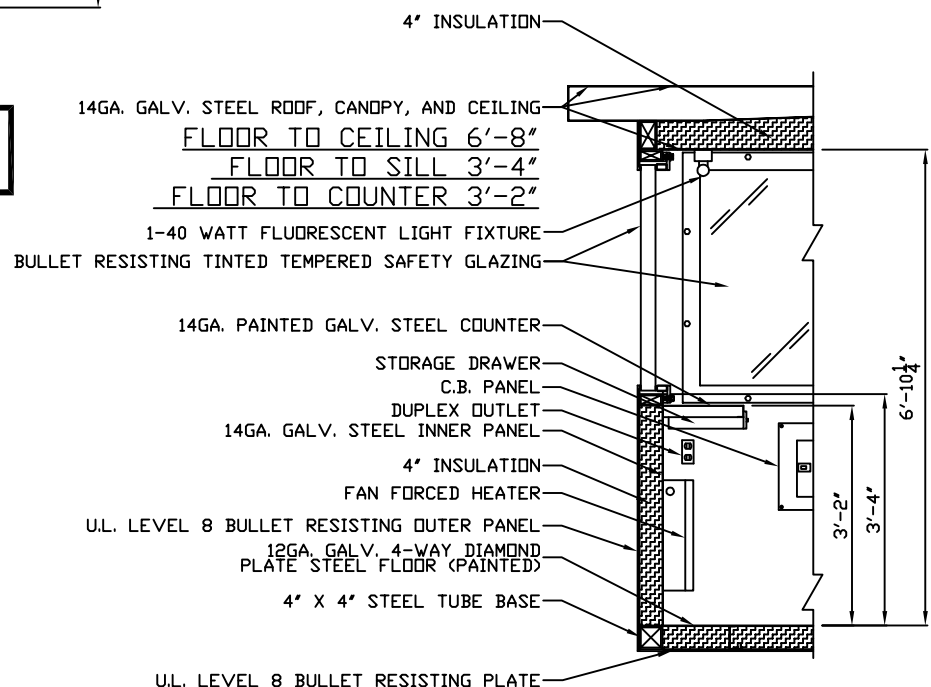

- COUNTER- 18" DEEP PAINTED GALVANIZED STEEL MOUNTED 38".
- PAINTED STORAGE DRAWER MOUNTED BENEATH COUNTER.
- DOOR- 30" WIDE U.L. LEVEL 8 BULLET RESISTING SWINGING STEEL WITH WEATHER-STRIPPING, BALL BEARING BUTTS, BULLET RESISTING SAFETY GLAZING, HYDRAULIC CLOSER, PANIC EXIT DEVICE WITH LEVER HANDLE EXTERIOR TRIM, AND HARDWARE.
- HOLE IN COUNTER FOR DROP CORD.
- DUPLEX OUTLET MOUNTED BELOW COUNTER.
- FLUORESCENT LIGHT FIXTURE.
- HEATER- 240V/4,800 WATT WALL MOUNTED WITH INTEGRAL THERMOSTAT CONTROL.
- 75 WATT DUPLEX FLOODLIGHT MOUNTED AT SOFFIT FLUSH WITH OVERHANG, 4-REQ'D.
- 1" SERVICE ENTRANCE NIPPLE THROUGH WALL TO BACK OF C.B. PANEL.
- PORTABLE GENERATOR 4 KW MIN. MOUNTED AT TONGUE.
- AIR CONDITIONER- 120V/13,500 BTU ROOF MOUNTED WITH INTEGRAL THERMOSTAT CONTROL.
- C.B. PANEL- 12 SPACE 120/240V 1Ø-3 WIRE WITH GROUND. 100 AMP MAIN BREAKER INCLUDED.
- 10' POWER CORD WITH WITH MALE PLUG.

NOTE: THE FOLLOWING ITEMS MAKE UP HEAVY DUTY TRAILER:

- GRIP STRUT FOLD DOWN STEP.
- LEVELING JACK, 4-REQ'D.
- 12GA. GALV. 4-WAY DIAMOND PLATE STEEL TRAILER BED.
- 1" X 1" SAFETY RAILS.
- BALL COUPLER.
- FIXED TONGUE WITH TONGUE JACK AND SAFETY CHAINS.
- TIRES, 4-REQ'D.

NOTE: PAR-KUT BOOTHS ARE OF SINGLE UNIT WELDED GALVANIZED STEEL CONSTRUCTION, FACTORY ASSEMBLED AND DELIVERED SET UP. FAILURE TO SECURELY ANCHOR BOOTH MAY RESULT IN OVERTURNING OF UNIT AND SERIOUS INJURY TO OCCUPANT.

- A. SAFETY GLAZING- BULLET RESISTING TINTED SAFETY GLAZING SET IN PAINTED STEEL WINDOW FRAMES.
- B. PAINT- A RUST INHIBITIVE PRIMER WITH AN INDUSTRIAL FINISH.
- C. ELECTRICAL- ALL WIRING BY PAR-KUT TO BE #12(MIN) STRANDED COPPER, THHN ENCLOSED IN 1/2"(MIN) E.M.T. PER NATIONAL ELECTRIC CODE. FITTINGS, FIXTURES, AND DEVICES ARE U.L. LABELED. ALL WIRING TO TERMINATE AT C.B. PANEL. ALL CIRCUITS HAVE GREEN GROUND WIRE.
- D. BOOTH WILL HAVE 12" CANOPY OVERHANG ON ALL SIDES.
- E. LIFTING RING(S) ARE PROVIDED IN ROOF.
- F. NO ON SITE WORK BY PAR-KUT.
- G. OUTER PANELS, DOOR, SAFETY GLAZING, AND FLOOR TO MEET U.L. 752 LEVEL 8 STANDARDS.
- H. CANOPY OVERHANG, CEILING, ROOF, TRAILER, AND AIR CONDITIONER ARE NOT BULLET RESISTING.

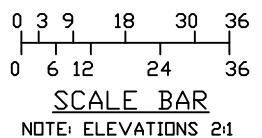

GENERAL NOTES		
PAINT COLOR: (PLEASE SPECIFY COLOR)		
PO#	SCALE	DRAWN BY
NTS	NSG	NSG
DATE	SIZE	QTY
CHK'D BY:	6' X 8'	SALES REPRESENTATIVE

NOTE: THIS PRINT AND DESIGN ARE THE PROPERTY OF PAR-KUT INTERNATIONAL, INC. IT MUST NOT BE REPRODUCED IN ANY MANNER, NOR SHALL IT BE SUBMITTED TO OUTSIDE PARTIES FOR EXAMINATION WITHOUT OUR CONSENT. IT SHALL BE USED ONLY AS A MEANS OF REFERENCE TO WORK DESIGNED AND FURNISHED BY PAR-KUT. PAR-KUT RESERVES THE RIGHT TO MAKE CHANGES TO DESIGN FOR ENGINEERING PURPOSES WITHOUT NOTICE. REVISIONS MAY NOT BE NOTED.

PAR-KUT INTERNATIONAL, INC.
 40961 Production Drive
 Harrison Twp, Mich.
 48045-1551
 Ph. (586) 468-2947

DWG# SEC-013 SHEET A-1

6' X 8' TRAILER