

- a. 6' X 18" SLOT IN FLOOR FOR ELECTRIC SERVICE ENTRANCE TO C.B. PANEL ABOVE, 2-REQ'D.
- b. 6' X 12" SLOT IN FLOOR FOR COMMUNICATION SERVICE ENTRANCE, 2-REQ'D.
- c. 6' X 9" SLOT IN FLOOR FOR COMMUNICATION SERVICE ENTRANCE.
- d. 2" X 2" X 1/4" MIN. ANCHOR CLIP WITH 3/4" ANCHOR BOLT HOLE, 4-REQ'D. ONE EACH CORNER. ANCHOR BOOTH AFTER FINAL LOCATION. ANCHOR BOLTS NOT INCLUDED.
- e. OUTER EDGE OF BASE

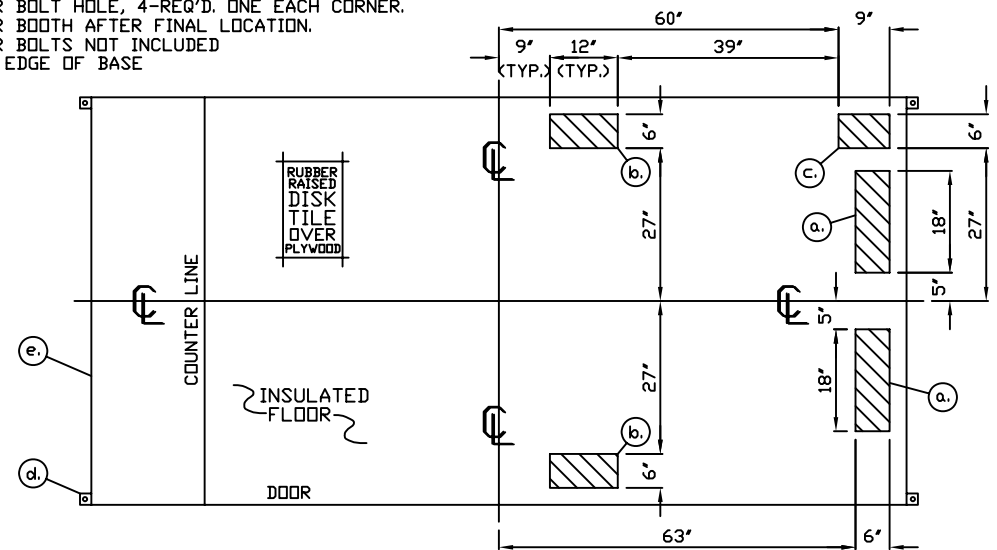

NOTE: PROVIDE 120/240V. 1Ø-3 WIRE SERVICE WITH GROUND.
SERVICE ENTRANCE/ANCHOR BOLT LAYOUT

1. COUNTER- 18" DEEP GALVANIZED STEEL WITH 1/2" PARTICLE BOARD AND PLASTIC LAMINATE TOP AND EDGE MOUNTED 32" ABOVE FLOOR.
2. PAINTED STORAGE DRAWER BENEATH COUNTER.
3. DOOR- 30" WIDE, SLIDING STEEL WITH WEATHER-STRIPPING, BALL BEARING HANGERS, SAFETY GLAZING, HEAVY DUTY TRACK, HOOK BOLT LOCK, & HARDWARE.
4. 1-1/4" HOLE IN COUNTER FOR DROP CORDS TO OUTLET, 2-REQ'D.
5. DUPLEX OUTLET- MOUNTED BELOW COUNTER, 2-REQ'D.
6. SIDE SLIDING CASHIER WINDOW WITH TINTED INSULATED GLAZING.
7. LIGHT SWITCH MOUNTED BELOW COUNTER FOR INTERIOR LIGHTS.
8. LIGHT- 2-34 WATT FLUORESCENT RECESSED LIGHT FIXTURE WITH LENS, 2-REQ'D.
9. SWITCH WITH TWO 3/4" RACEWAYS & PULL WIRES TO STUB ABOVE ROOF FOR FUTURE USE.
10. HEATER- 240V./5,600 WATT FAN FORCED WITH INTEGRAL THERMOSTAT CONTROL.
11. AIR CONDITIONER 120V./13,500 BTU ROOF MOUNTED WITH INTEGRAL THERMOSTAT CONTROL.
12. C.B. PANEL- 12 SPACE 120/240V. 1Ø-3 WIRE WITH GROUND BAR. 100 AMP MAIN BREAKER IS INCLUDED.
13. ANCHOR CLIP- 2" X 2" X 1/4" MIN. STEEL WELDED TO BASE AT GRADE WITH 3/4" ANCHOR BOLT HOLE. 4-REQ'D. ANCHOR BOOTH AFTER FINAL LOCATION. ANCHOR BOLTS NOT INCLUDED.

NOTE: PAR-KUT BOOTHS ARE OF SINGLE UNIT WELDED GALVANIZED STEEL CONSTRUCTION, FACTORY ASSEMBLED AND DELIVERED SET UP. FAILURE TO SECURELY ANCHOR BOOTH MAY RESULT IN OVERTURNING OF UNIT AND SERIOUS INJURY TO OCCUPANT.

- A. GLAZING TO BE GRAY TINTED INSULATED SAFETY GLAZING WITH PAINTED STEEL EXTERIOR WINDOW FRAMES AND PAINTED ALUMINUM INTERIOR GLAZING STOPS.
- B. PAINT- A RUST INHIBITIVE PRIMER WITH AN INDUSTRIAL FINISH.
- C. ELECTRICAL- ALL WIRING BY PAR-KUT TO BE #12(MIN) STRANDED COPPER, THHN ENCLOSED IN 1/2"(MIN) E.M.T. PER NATIONAL ELECTRIC CODE. FITTINGS, FIXTURES & DEVICES ARE U.L. LABELED. ALL WIRING TO TERMINATE AT C.B. PANEL. ALL CIRCUITS HAVE GREEN GROUND WIRE.
- D. BOOTH WILL HAVE A 3" CANOPY OVERHANG ON ALL SIDES.
- E. LIFTING RING(S) ARE PROVIDED IN ROOF.
- F. NO ON SITE WORK BY PAR-KUT.

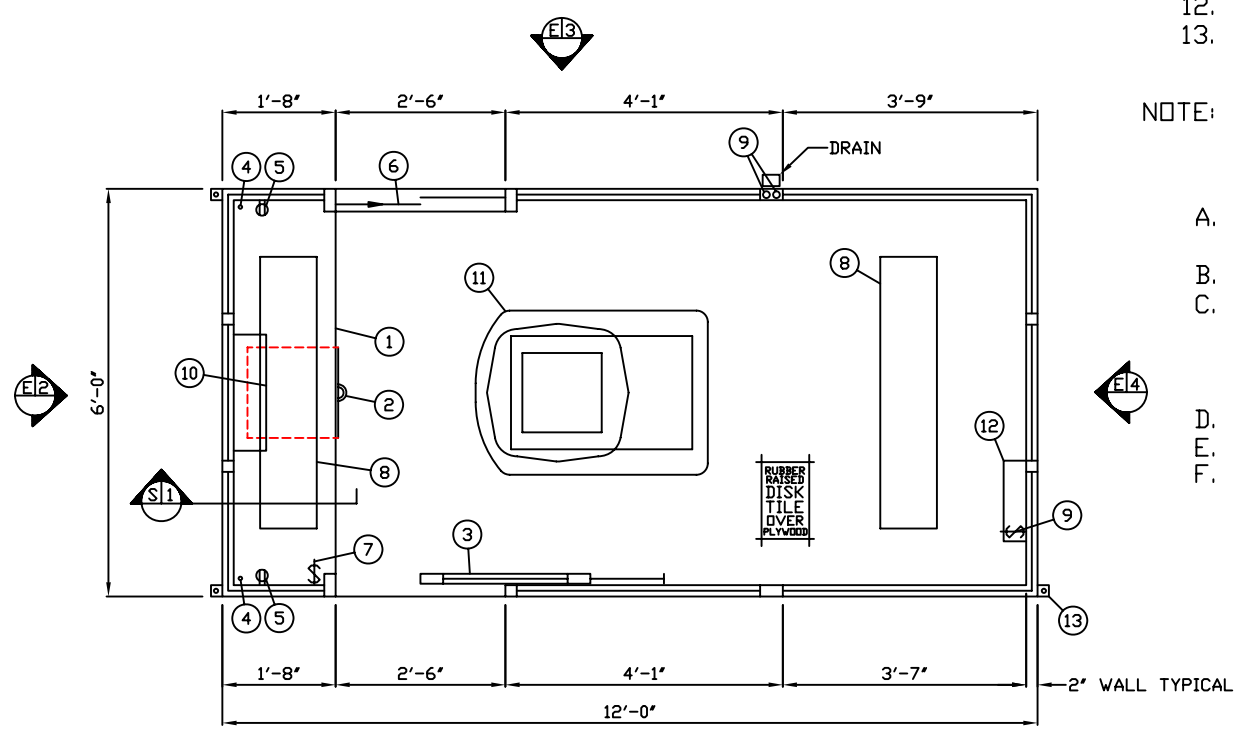

PLAN VIEW

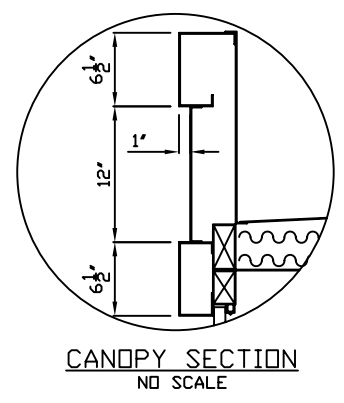

CANOPY SECTION
NO SCALE

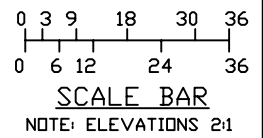

SCALE BAR
NOTE: ELEVATIONS 2:1

NOTE: THIS PRINT AND DESIGN ARE THE PROPERTY OF PAR-KUT INTERNATIONAL, INC. IT MUST NOT BE REPRODUCED IN ANY MANNER, NOR SHALL IT BE SUBMITTED TO OUTSIDE PARTIES FOR EXAMINATION WITHOUT OUR CONSENT. IT SHALL BE USED ONLY AS A MEANS OF REFERENCE TO WORK DESIGNED AND FURNISHED BY PAR-KUT. PAR-KUT RESERVES THE RIGHT TO MAKE CHANGES TO DESIGN FOR ENGINEERING PURPOSES WITHOUT NOTICE. REVISIONS MAY NOT BE NOTED.

PAR-KUT INTERNATIONAL, INC.
40961 Production Drive
Harrison Twp, Mich.
48049-1351
PH. (810) 468-2947

DWG# CUST-010 SHEET A-1

A/E NOTES	
PAIN COLOR:	
PLASTIC LAMINATE:	COMPLIMENTARY COLOR
RUBBER TILE COLOR:	COMPLIMENTARY COLOR
EXTERIOR WALL PANELS SHALL BE BRACED FLAT WITH 3/8" EXTERIOR GRADE PLYWOOD AFFIXED.	
BASE TUBE TO PROTRUDE 3/8" BEYOND EXTERIOR WALLS	

6' X 12' CUSTOM BOOTH	
SCALE	DRAWN BY
DATE	SIZE
CHK'D BY:	SALES REPRESENTATIVE