

PLAN VIEW  
SCALE: 3/4"=1'-0"

1. COUNTER- 22" DEEP 304-2B STAINLESS STEEL 32" ABOVE FLOOR, 2-REQ'D.
2. PAINTED STORAGE DRAWER WITH STAINLESS STEEL FACE MOUNTED BENEATH COUNTER, 2-REQ'D.
3. DOOR- 30" WIDE, SLIDING STEEL WITH WEATHER-STRIPPING, BALL BEARING HANGERS, SAFETY GLAZING, HEAVY DUTY TRACK, HOOK BOLT LOCK, & HARDWARE, 2-REQ'D.
4. SINGLE RECEPTACLE FOR AIR CONDITIONER UNIT.
5. DUPLEX OUTLETS MOUNTED ABOVE COUNTER, 14-REQ'D.
6. 3-WAY LIGHT SWITCH MOUNTED ABOVE COUNTER FOR INTERIOR FRONT LIGHT, 2-REQ'D.
7. 3-WAY LIGHT SWITCH MOUNTED ABOVE COUNTER FOR INTERIOR REAR LIGHT, 2-REQ'D.
8. LIGHT- 2-34 WATT LAMP FLUORESCENT LIGHT FIXTURE WITH LENS, 2-REQ'D.
9. LIGHT SWITCH MOUNTED ABOVE COUNTER FOR EXTERIOR LIGHTS.
10. EXTERIOR HIGH PRESSURE SODIUM FLOOD LIGHT MOUNTED ON ROOF WITH 150 WATT LAMP, 2-REQ'D.
11. COMBINATION HEAT/COOL UNIT- 240V./11,600 BTU WALL MOUNTED WITH INTEGRAL THERMOSTAT CONTROL.
12. C.B. PANEL- 12 SPACE 120/240V. 1Ø-3 WIRE WITH GROUND BAR. 100 AMP MAIN BREAKER IS INCLUDED.
13. 1-1/4" HOLE IN COUNTER FOR DROP CORDS TO OUTLET, 14-REQ'D.
14. CASHIER WINDOW IN SLIDING DOOR, 2-REQ'D.
15. CONCEALED ANCHOR CLIP STEEL WELDED TO BASE AT GRADE WITH 1" ANCHOR BOLT HOLE. 4-REQ'D. ANCHOR BOOTH AFTER FINAL LOCATION. USING 3/4" X 5-1/2" RAWL STUD ANCHORS. ANCHOR BOLTS NOT INCLUDED.
16. 8" X 8" X 3/16" STAINLESS STEEL PLATE WITH (4) 1" ANCHOR BOLT HOLES. ANCHOR BOOTH AFTER FINAL LOCATION USING (4) 3/4" X 4-1/4" RAWL STUD ANCHORS AT EACH COLUMN PLATE. ANCHOR BOLTS NOT INCLUDED, 2-REQ'D.

NOTE: PAR-KUT BOOTHS ARE OF SINGLE UNIT WELDED GALVANIZED STEEL CONSTRUCTION, FACTORY ASSEMBLED AND DELIVERED SET UP. FAILURE TO SECURELY ANCHOR BOOTH MAY RESULT IN OVERTURNING OF UNIT AND SERIOUS INJURY TO OCCUPANT.

- A. GLAZING TO BE 1/4" GRAY TINTED TEMPERED SAFETY GLAZING WITH PAINTED STEEL EXTERIOR GLAZING STOPS AND ALUMINUM INTERIOR GLAZING STOPS.
- B. PAINT- A RUST INHIBITIVE PRIMER WITH AN INDUSTRIAL FINISH.
- C. ELECTRICAL- ALL WIRING BY PAR-KUT TO BE #12(MIN) STRANDED COPPER, THHN ENCLOSED IN 1/2"(MIN) E.M.T. PER NATIONAL ELECTRIC CODE. FITTINGS, FIXTURES & DEVICES ARE U.L. LABELED. ALL WIRING TO TERMINATE AT C.B. PANEL. ALL CIRCUITS HAVE GREEN GROUND WIRE.
- D. BOOTH WILL HAVE A 20" CANOPY OVERHANG ON THREE SIDES AND 72" ON OTHER SIDE.
- E. LIFTING RING(S) ARE PROVIDED IN ROOF.
- F. NO ON SITE WORK BY PAR-KUT.

- a. 6" X 12" SLOT IN FLOOR FOR ELECTRIC SERVICE ENTRANCE INTO BOOTH, 2-REQ'D.
- b. 8" X 8" SLOT IN FLOOR, 2-REQ'D.
- c. CONCEALED ANCHOR CLIP WITH 3" DIAMETER ACCESS HOLE & COVER WITH 1" ANCHOR BOLT HOLE IN 1/4" PLATE GUSSET. 4-REQ'D. ONE EACH CORNER. ANCHOR BOOTH AFTER FINAL LOCATION USING 3/4" X 5-1/2" RAWL STUD ANCHORS. ANCHOR BOLTS NOT INCLUDED.
- d. OUTER EDGE OF BASE
- e. 2" RIGID CONDUIT FROM SLOT TO SLOT, 2-REQ'D.
- f. 8" X 8" X 3/16" STAINLESS STEEL PLATE WITH (4) 1" ANCHOR BOLT HOLES. ANCHOR BOOTH AFTER FINAL LOCATION USING (4) 3/4" X 4-1/4" RAWL STUD ANCHORS AT EACH COLUMN PLATE. ANCHOR BOLTS NOT INCLUDED, 2-REQ'D.
- g. 6" ROUND HEAVY WALL STEEL TUBE, 2-REQ'D.

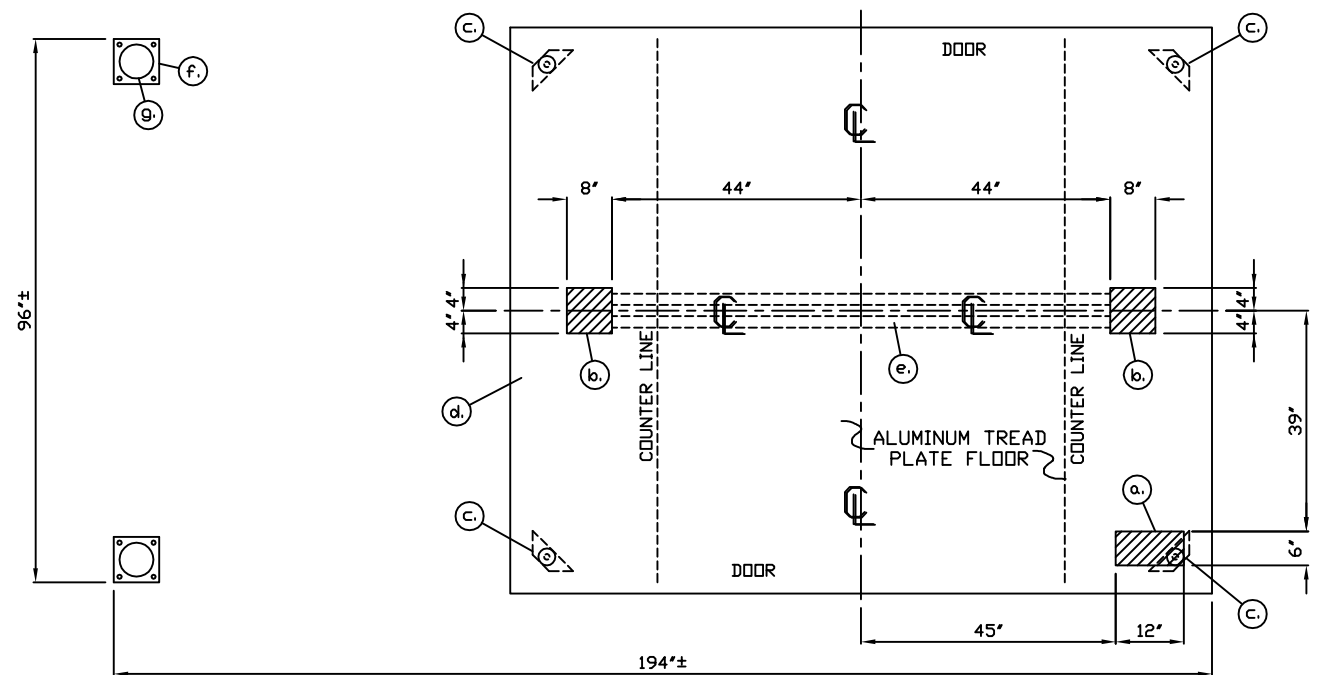

NOTE: PROVIDE 120/240V. 1Ø-3 WIRE SERVICE WITH GROUND.  
SERVICE ENTRANCE/ANCHOR BOLT LAYOUT

SCALE: 3/4"=1'-0"

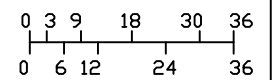

SCALE BAR  
NOTE: ELEVATIONS 2±

NOTE: THIS PRINT AND DESIGN ARE THE PROPERTY OF PAR-KUT INTERNATIONAL, INC. IT MUST NOT BE REPRODUCED IN ANY MANNER, NOR SHALL IT BE SUBMITTED TO OUTSIDE PARTIES FOR EXAMINATION WITHOUT OUR CONSENT. IT SHALL BE USED ONLY AS A MEANS OF REFERENCE TO WORK DESIGNED AND FURNISHED BY PAR-KUT. PAR-KUT RESERVES THE RIGHT TO MAKE CHANGES TO DESIGN FOR ENGINEERING PURPOSES WITHOUT NOTICE. REVISIONS MAY NOT BE NOTED.

PAR-KUT INTERNATIONAL, INC.  
40961 Production Drive  
Harrison Twp, Mich.  
48045-1351  
PH. (810) 468-2947



DWG# 2K226 SHEET A-1

INDUSTRIAL TIME & SYSTEMS  
BAYER PHARMACEUTICALS  
WESTHAVEN, CT

PD# VERBAL	DRAWN BY	REVISED
SCALE AS NOTED	AJP	11-6-2014
DATE	SIZE	QTY
3-30-2000	8' X 10'	1
CHK'D BY:	SALES REPRESENTATIVE	
	TOM DUEMLING	

A/E NOTES

INTERIOR POLYURETHANE PAINT COLOR: POLAR GRAY #71537  
EXTERIOR PANELS, DOOR, AND SOFFIT POLYURETHANE PAINT COLOR TO BE: POLAR GRAY #71537  
EXTERIOR DRAIN, MULLIONS, AND CANOPY COLUMNS POLYURETHANE PAINT COLOR TO BE: SILVER MET #43523  
EXTERIOR FASCIA POLYURETHANE PAINT COLOR TO BE: CHAMPAGNE MET #F2997

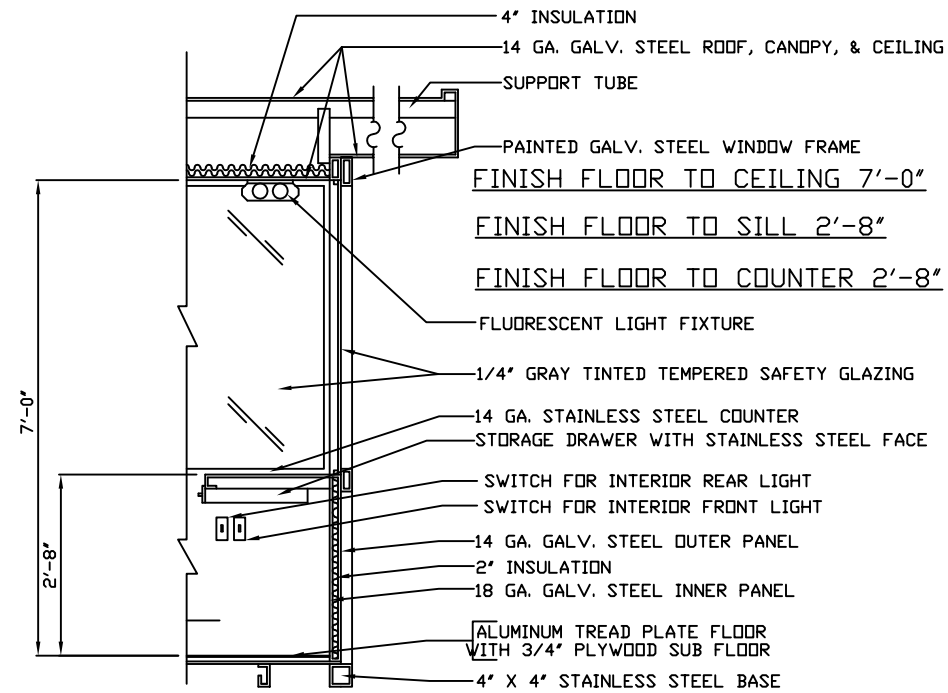
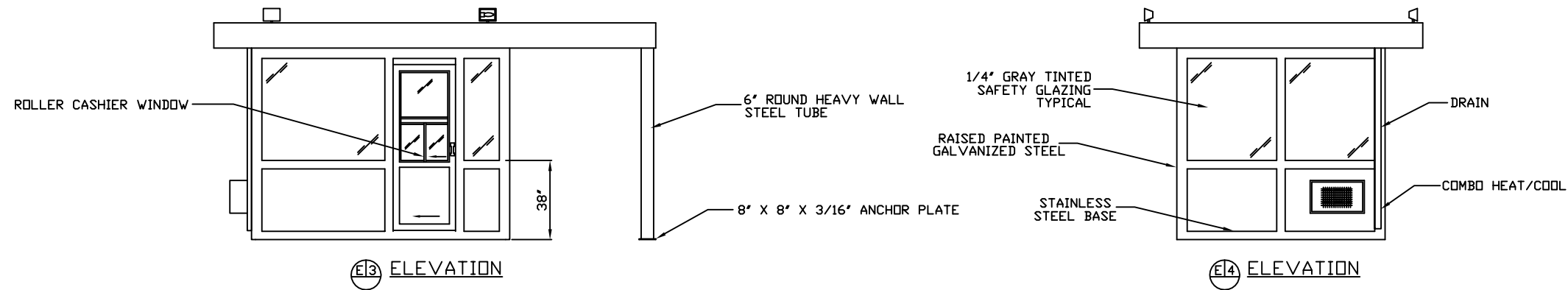
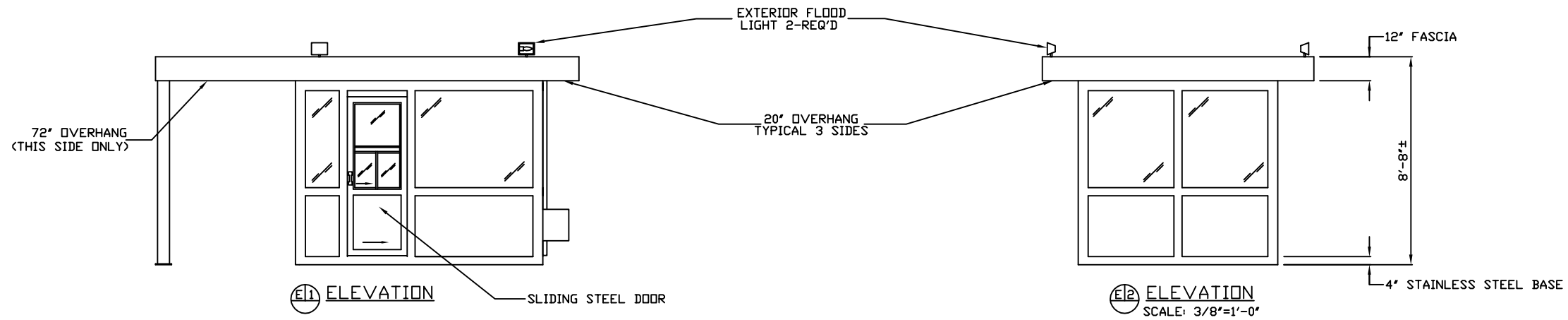

SECTION 1S  
NO SCALE

SUPPORT TUBES AND ANCHOR PLATES NOT SHOWN FOR CLARITY

NOTE: THIS PRINT AND DESIGN ARE THE PROPERTY OF PAR-KUT INTERNATIONAL, INC. IT MUST NOT BE REPRODUCED IN ANY MANNER, NOR SHALL IT BE SUBMITTED TO OUTSIDE PARTIES FOR EXAMINATION WITHOUT OUR CONSENT. IT SHALL BE USED ONLY AS A MEANS OF REFERENCE TO WORK DESIGNED AND FURNISHED BY PAR-KUT. PAR-KUT RESERVES THE RIGHT TO MAKE CHANGES TO DESIGN FOR ENGINEERING PURPOSES WITHOUT NOTICE. REVISIONS MAY NOT BE NOTED.

PAR-KUT INTERNATIONAL, INC.  
40961 Production Drive  
Harrison Twp, Mich.  
48045-1351  
PH. (810) 468-2947



DWG# 2K226 SHEET A-2

INDUSTRIAL TIME & SYSTEMS  
BAYER PHARMACEUTICALS  
WESTHAVEN, CT

PD# VERBAL	DRAWN BY	REVISED
SCALE NTS	AJP	11-6-2014
DATE 3-30-2000	SIZE 8' X 10'	QTY 1
CHK'D BY:	SALES REPRESENTATIVE TOM DUEMPLING	

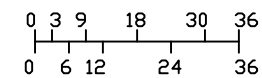

SCALE BAR  
NOTE: ELEVATIONS 2:1