

- a. 3" X 6" SLOT IN FLOOR FOR ELECTRIC SERVICE ENTRANCE TO C.B. PANEL ABOVE
- b. 2" X 2" X 1/4" MIN. ANCHOR CLIP WITH 3/4" ANCHOR BOLT HOLE, 4-REQ'D. ONE EACH CORNER. ANCHOR BOOTH AFTER FINAL LOCATION. ANCHOR BOLTS NOT INCLUDED
- c. OUTER EDGE OF BASE

A.D.A. NOTE
 BOOTH MUST BE HANDICAP ACCESSIBLE. THE FOUNDATION MAY BE RECESSED OR A 1:12 RAMP MUST BE PROVIDED SO THAT MAXIMUM CHANGE IN LEVEL FROM GRADE TO FINISH FLOOR DOES NOT EXCEED 1/4"

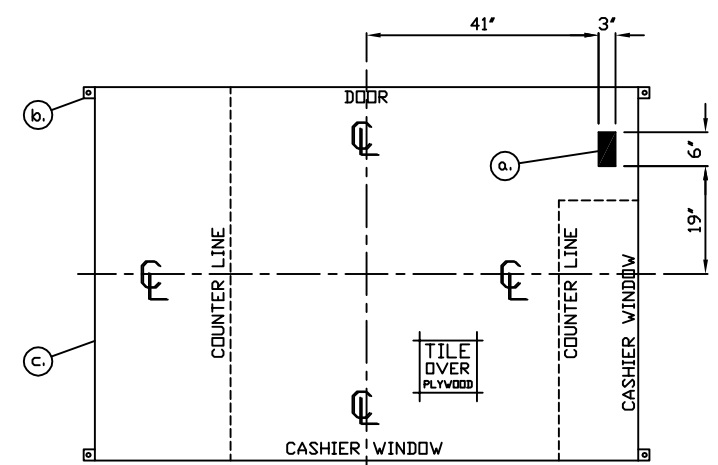
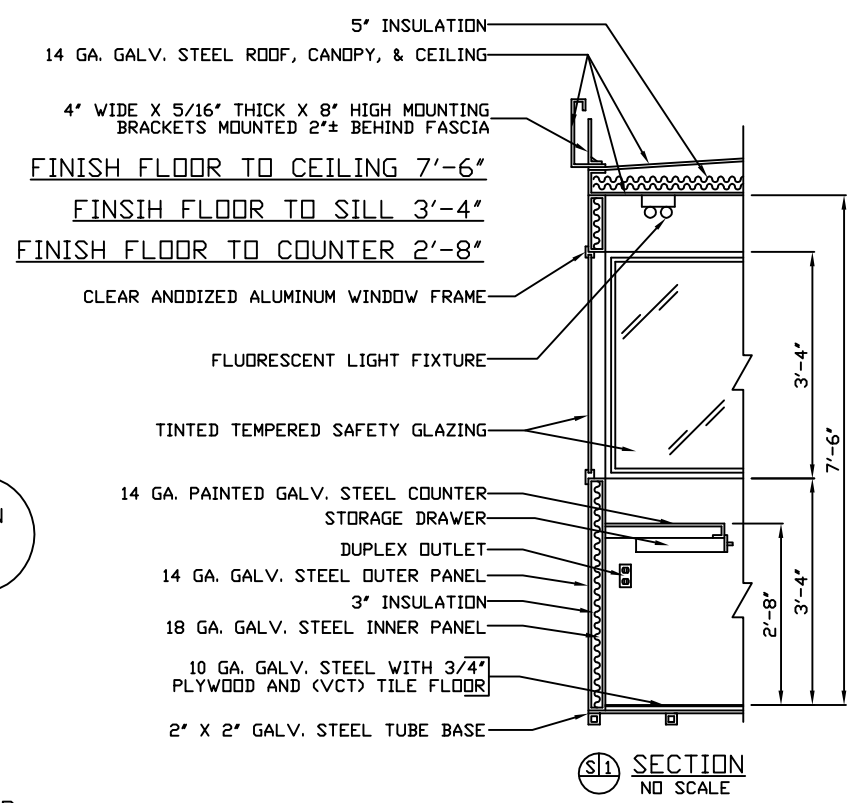

1. COUNTER- 22" DEEP PAINTED GALVANIZED STEEL 32" ABOVE FINISH FLOOR.
2. PAINTED STORAGE DRAWER BENEATH COUNTER.
3. DOOR- 36" WIDE, SWINGING STEEL WITH WEATHER-STRIPPING, BALL BEARING BUTTS, SAFETY GLAZING, HYDRAULIC CLOSER, LEVER HANDLE LOCK, & HARDWARE.
4. 1-1/4" HOLE IN COUNTER FOR DROP CORDS, 4-REQ'D.
5. DUPLEX OUTLET- MOUNTED BELOW COUNTER, 2-REQ'D.
6. QUAD OUTLET- MOUNTED BELOW COUNTER, 2-REQ'D.
7. 12" X 24" STAINLESS STEEL EXTERIOR SHELF.
8. SIDE SLIDING CASHIER WINDOW, 2-REQ'D.
9. LIGHT SWITCH FOR INTERIOR LIGHTS.
10. LIGHT- 2-34 WATT FLUORESCENT STRIP LIGHT FIXTURE, 2-REQ'D.
11. HEATER- 240V./5,600 WATT FAN FORCED WITH INTEGRAL THERMOSTAT CONTROL.
12. WALL MOUNTED THERMOSTAT CONTROL FOR ROOF TOP AIR CONDITIONER.
13. AIR CONDITIONER- 120V./13,500 BTU ROOF TOP WITH WALL MOUNTED THERMOSTAT CONTROL.
- * 14. BOLT IN SHELF- 12" DEEP PAINTED GALVANIZED STEEL 32" ABOVE FINISH FLOOR. (SHIPPED LOOSE)*
15. C.B. PANEL- 24 SPACE 120/240V. 1Ø-3 WIRE WITH GROUND BAR. 200 AMP MAIN BREAKER IS INCLUDED.
16. ANCHOR CLIP- 2" X 2" X 1/4" MIN. STEEL WELDED TO BASE AT GRADE WITH 3/4" ANCHOR BOLT HOLE. 4-REQ'D. ANCHOR BOOTH AFTER FINAL LOCATION. ANCHOR BOLTS NOT INCLUDED.
17. JUNCTION BOX WITH TOGGLE SWITCH NEAR C.B. PANEL WITH 3/4" CONDUIT RACEWAY TO STUB ABOVE ROOF NO WIRING.

NOTE: PAR-KUT BOOTHS ARE OF SINGLE UNIT WELDED GALVANIZED STEEL CONSTRUCTION, FACTORY ASSEMBLED AND DELIVERED SET UP. FAILURE TO SECURELY ANCHOR BOOTH MAY RESULT IN OVERTURNING OF UNIT AND SERIOUS INJURY TO OCCUPANT.

- A. GLAZING TO BE TINTED TEMPERED SAFETY GLAZING SET IN CLEAR ANODIZED ALUMINUM WINDOW FRAMES.
- B. PAINT- A RUST INHIBITIVE PRIMER WITH AN INDUSTRIAL FINISH.
- C. ELECTRICAL- ALL WIRING BY PAR-KUT TO BE #12(MIN) STRANDED COPPER, THHN ENCLOSED IN 1/2"(MIN) E.M.T. PER NATIONAL ELECTRIC CODE. FITTINGS, FIXTURES & DEVICES ARE U.L. LABELED. ALL WIRING TO TERMINATE AT C.B. PANEL. ALL CIRCUITS HAVE GREEN GROUND WIRE.
- D. BOOTH WILL HAVE A 3" CANOPY OVERHANG ON ALL SIDES.
- E. LIFTING RING(S) ARE PROVIDED IN ROOF.
- F. NO ON SITE WORK BY PAR-KUT.

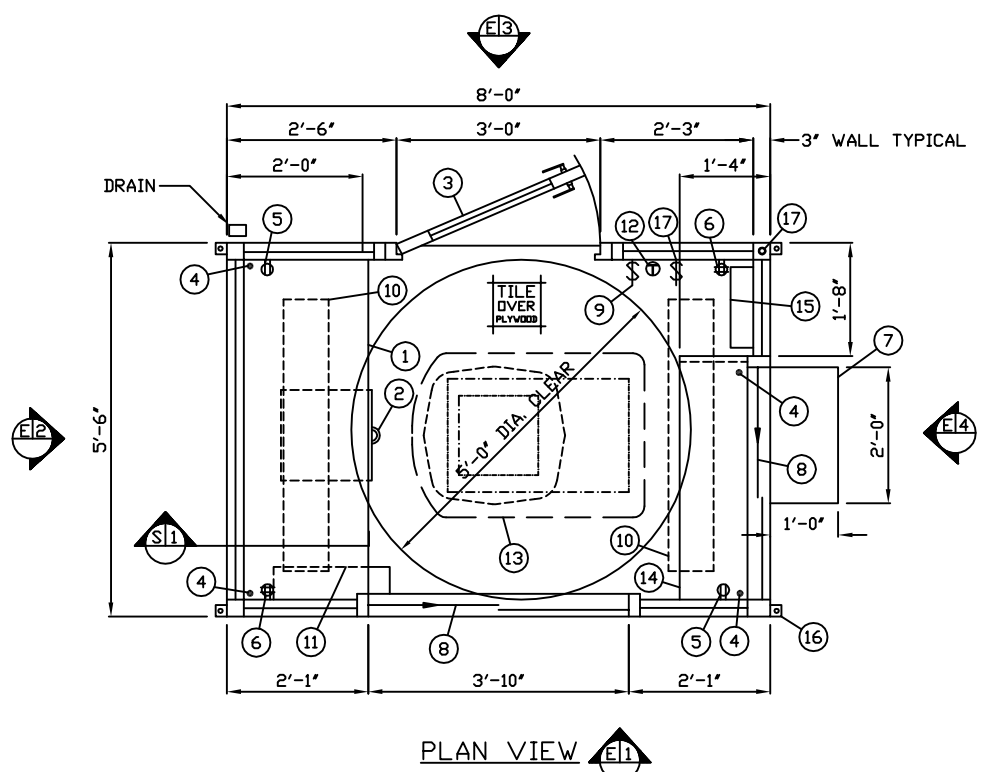

* N.E.C. ARTICLE 110-26 (a) (2) REQUIRES A 30" WIDE CLEAR WORKING SPACE

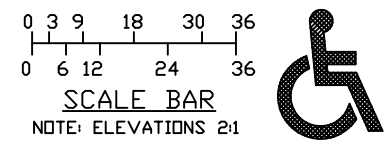

NOTE: THIS PRINT AND DESIGN ARE THE PROPERTY OF PAR-KUT INTERNATIONAL, INC. IT MUST NOT BE REPRODUCED IN ANY MANNER, NOR SHALL IT BE SUBMITTED TO OUTSIDE PARTIES FOR EXAMINATION WITHOUT OUR CONSENT. IT SHALL BE USED ONLY AS A MEANS OF REFERENCE TO WORK DESIGNED AND FURNISHED BY PAR-KUT. PAR-KUT RESERVES THE RIGHT TO MAKE CHANGES TO DESIGN FOR ENGINEERING PURPOSES WITHOUT NOTICE. REVISIONS MAY NOT BE NOTED.

PAR-KUT INTERNATIONAL, INC.
 40961 Production Drive
 Harrison Twp, Mich.
 48045-1351
 PH. (810) 468-2947

DWG# 01-128 SHEET A-1

UP FRONT MALL PARKING
 C/O DENNISON PARKING INC.
 BOCA RATON, FL

SCALE NTS	DRAWN BY AJP	REVISED 11-6-2014
DATE 2-5-2001	SIZE 5'-6" X 8'	QTY 1
CHK'D BY:	SALES REPRESENTATIVE TOM DUEMLING	

A/E NOTES

PAIN T COLOR:	
TINTED GLAZING COLOR: GRAY OR BRONZE	
(PLEASE SPECIFY COLORS)	
(VCT) TILE COLOR:	COMPLIMENTARY COLOR