

- COUNTER - PAINTED GALVANIZED STEEL MOUNTED AT SILL.
- PAINTED STORAGE DRAWER.
- DOOR - SLIDING STEEL WITH WEATHER-STRIPPING, BALL BEARING HANGERS, HEAVY DUTY TRACK, SAFETY GLAZING, HOOK BOLT LOCK WITH REMOVABLE CYLINDER, AND INSIDE THUMB TURN.
- HOLE IN COUNTER FOR DROP CORDS.
- DUPLEX OUTLET MOUNTED BELOW COUNTER.
- FLUORESCENT LIGHT FIXTURE WITH T-8 LAMP INCLUDED.
- WALL SWITCH FOR INTERIOR LIGHT.
- HEATER - WALL MOUNTED WITH INTEGRAL THERMOSTAT CONTROL.
- 10' POWER CORD
- RAIN TIGHT CIRCUIT BREAKER PANEL - 12 SPACE, 120/240V, 1Ø-3 WIRE WITH GROUND BAR, 100 AMP MAIN BREAKER, AND ALL BRANCH BREAKERS FOR FACTORY INSTALLED DEVICES PROVIDED.

THE FOLLOWING ITEMS MAKE UP HEAVY DUTY TRAILER:

- GRIP STRUT FOLD DOWN STEP.
- LEVELING JACK, 4-REQ'D.
- 12GA. GALVANIZED, 4-WAY DIAMOND PLATE STEEL TRAILER BED.
- 1' X 1' SAFETY RAIL.
- 2' BALL COUPLER.
- TONGUE WITH TONGUE JACK AND SAFETY CHAINS.
- 13' TIRES, 2-REQ'D.

THE FOLLOWING ITEMS ARE THE FEDERAL LIGHTING EQUIPMENT LOCATION REQUIREMENTS:

- FRONT SIDE REFLEX REFLECTORS - MOUNTED 15-60' FROM GRADE AT EACH SIDE AT FRONT AS FAR FORWARD AS PRACTICABLE FACING SIDE WARD, 2-REQ'D(MIN).
- FRONT SIDE MARKER LAMPS - MOUNTED 15'(MIN) FROM GRADE AT EACH SIDE AT FRONT AS FAR FORWARD AS PRACTICABLE, 2-REQ'D(MIN).
- FRONT CLEARANCE LAMPS - MOUNTED AS HIGH AS PRACTICABLE AT WIDEST POINT SYMMETRICAL AS FAR FORWARD AS PRACTICABLE FACING FORWARD, 2-REQ'D(MIN).
- REAR SIDE REFLEX REFLECTORS - MOUNTED 15-60' ABOVE GRADE AT EACH SIDE AT REAR AS FAR BACK AS PRACTICABLE FACING SIDE WARD, 2-REQ'D(MIN).
- REAR CLEARANCE LAMPS - AS HIGH AS PRACTICABLE (MAY BE LOWER ONLY IF ID LAMPS ARE AT TOP) AT WIDEST POINT SYMMETRICAL ON THE REAR OR NEAR THE REAR FACING FORWARD, 2-REQ'D(MIN).
- REAR IDENTIFICATION LAMPS - AS HIGH AS PRACTICABLE ON THE REAR CENTER FACING FORWARD HORIZONTALLY SPACED 6-12' APART, 3-REQ'D.

NOTE: PAR-KUT BOOTHS ARE OF SINGLE UNIT WELDED STEEL CONSTRUCTION, FACTORY ASSEMBLED AND DELIVERED SET UP. FAILURE TO SECURELY ANCHOR BOOTH MAY RESULT IN OVERTURNING OF UNIT AND SERIOUS INJURY TO OCCUPANT.

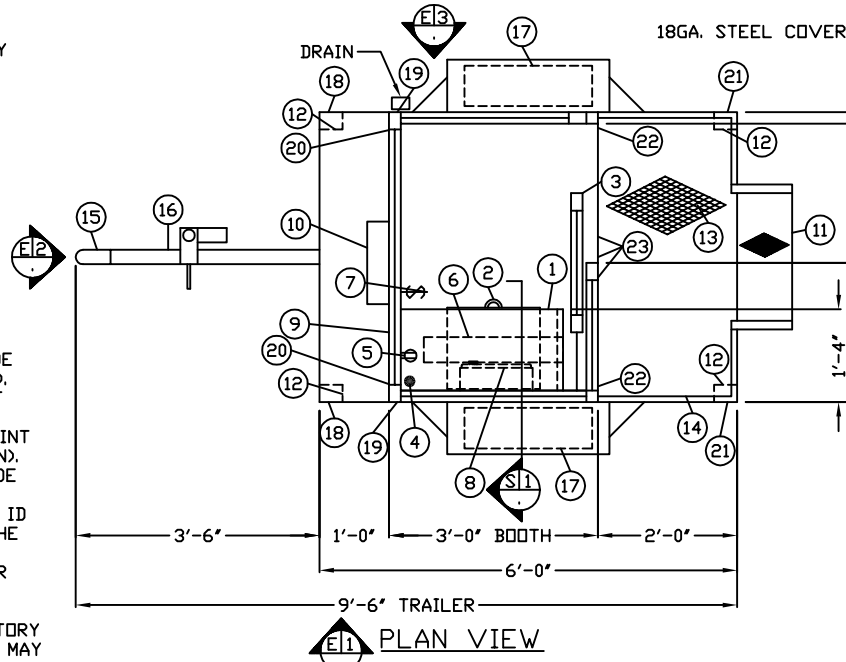

SECTION S1
NO SCALE
TRAILER NOT SHOWN
FOR CLARITY

NOTE: THIS PRINT AND DESIGN ARE THE PROPERTY OF PAR-KUT INTERNATIONAL, INC. IT MUST NOT BE REPRODUCED IN ANY MANNER, NOR SHALL IT BE SUBMITTED TO OUTSIDE PARTIES FOR EXAMINATION WITHOUT OUR CONSENT. IT SHALL BE USED ONLY AS A MEANS OF REFERENCE TO WORK DESIGNED AND FURNISHED BY PAR-KUT. PAR-KUT RESERVES THE RIGHT TO MAKE CHANGES TO DESIGN FOR ENGINEERING PURPOSES WITHOUT NOTICE. REVISIONS MAY NOT BE NOTED.

PAR-KUT INTERNATIONAL, INC.
40961 Production Drive
Harrison Twp, Mich.
48045-1351
Ph. (586) 468-2947
www.parkut.com



- GLAZING - SAFETY GLAZING SET IN ANODIZED ALUMINUM WINDOW FRAMES.
- PAINT - FINISH SHALL BE SINGLE COLOR OF CHOICE, IMRON POLYURETHANE HIGH GLOSS INDUSTRIAL COATING. SHALL BE APPLIED TO ALL EXPOSED METAL SURFACES. THIS EXCLUDES ROOF SURFACE, ANODIZED ALUMINUM WINDOW FRAMES AND ANY STAINLESS STEEL COMPONENTS (IF USED).
- ELECTRICAL - ALL WIRING BY PAR-KUT TO BE #12(MIN) STRANDED COPPER, THHN ENCLOSED IN 1/2"(MIN) E.M.T. PER NATIONAL ELECTRIC CODE. FITTINGS, FIXTURES, AND DEVICES ARE U.L. LABELED. ALL WIRING TO TERMINATE AT C.B. PANEL. ALL CIRCUITS HAVE GREEN GROUND WIRE.
- BOOTH WILL HAVE A 3' CANOPY OVERHANG ON ALL SIDES.
- LIFTING RING(S) ARE PROVIDED ON ROOF.
- NO ON SITE WORK BY PAR-KUT.

GENERAL NOTES		
PAINT COLOR: (PLEASE SPECIFY COLOR)		
PO#	SCALE	DRAWN BY
	NTS	JJD
DATE	SIZE	REVISED
6-29-2010	3' X 4'-2"	11-5-2014
CHK'D BY:		QTY
		SALES REPRESENTATIVE

DWG#	pk43t1r		SHEET	A-1
STANDARD 3' X 4'-2" BOOTH WITH TRAILER MODEL 43TLR				