

E1 ELEVATION

E3 ELEVATION

E4 ELEVATION

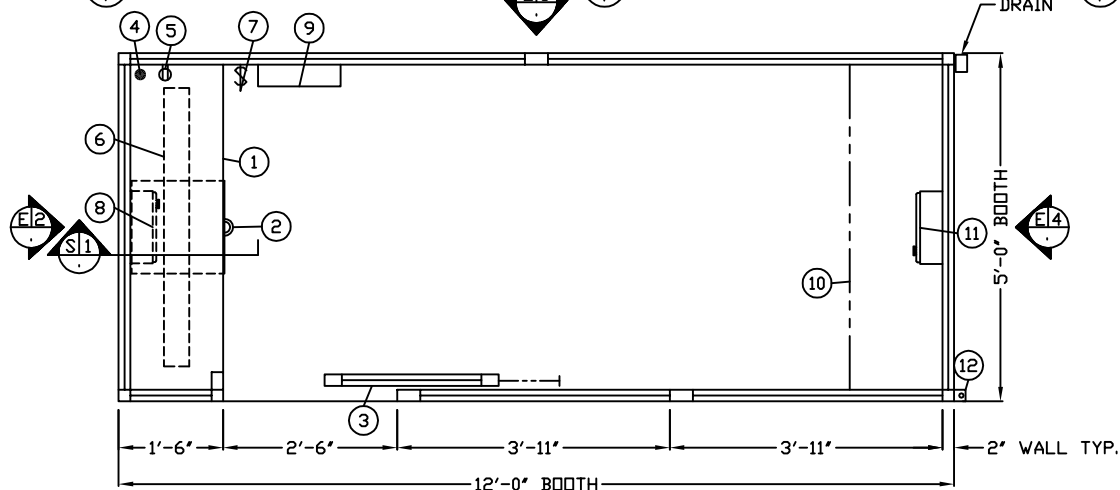

E1 PLAN VIEW

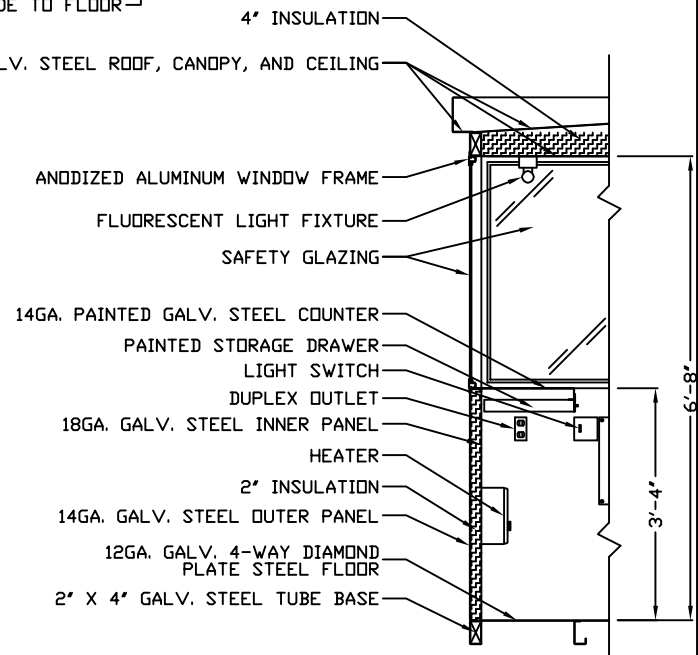

S1 SECTION
NO SCALE

1. COUNTER - PAINTED GALVANIZED STEEL MOUNTED AT SILL.
2. PAINTED STORAGE DRAWER.
3. DOOR - SLIDING STEEL WITH WEATHER-STRIPPING, BALL BEARING HANGERS, HEAVY DUTY TRACK, SAFETY GLAZING, HOOK BOLT LOCK WITH REMOVABLE CYLINDER, AND INSIDE THUMB TURN.
4. HOLE IN COUNTER FOR DROP CORDS.
5. DUPLEX OUTLET MOUNTED BELOW COUNTER.
6. FLUORESCENT LIGHT FIXTURE WITH T-8 LAMP INCLUDED.
7. WALL SWITCH FOR INTERIOR LIGHT.
8. HEATER - WALL MOUNTED WITH INTEGRAL THERMOSTAT CONTROL.
9. CIRCUIT BREAKER PANEL - 12 SPACE, 120/240V, 1Ø-3 WIRE WITH GROUND BAR, 100 AMP MAIN BREAKER, AND ALL BRANCH BREAKERS FOR FACTORY INSTALLED DEVICES PROVIDED.
10. OPTIONAL COUNTER
11. OPTIONAL HEATER
12. ANCHOR CLIP - 2" X 2" X ¼"(MIN) STEEL WITH A ¾" ANCHOR BOLT HOLE, 4-REQ'D, WELDED TO BASE AT GRADE. ANCHOR BOOTH AFTER FINAL LOCATION. ANCHOR BOLTS NOT INCLUDED.

NOTE: PAR-KUT BOOTHS ARE OF SINGLE UNIT WELDED STEEL CONSTRUCTION, FACTORY ASSEMBLED AND DELIVERED SET UP. FAILURE TO SECURELY ANCHOR BOOTH MAY RESULT IN OVERTURNING OF UNIT AND SERIOUS INJURY TO OCCUPANT.

- A. GLAZING - SAFETY GLAZING SET IN ANODIZED ALUMINUM WINDOW FRAMES.
- B. PAINT - FINISH SHALL BE SINGLE COLOR OF CHOICE, IMRON POLYURETHANE HIGH GLOSS INDUSTRIAL COATING. SHALL BE APPLIED TO ALL EXPOSED METAL SURFACES. THIS EXCLUDES ROOF SURFACE, ANODIZED ALUMINUM WINDOW FRAMES AND ANY STAINLESS STEEL COMPONENTS (IF USED).
- C. ELECTRICAL - ALL WIRING BY PAR-KUT TO BE #12(MIN) STRANDED COPPER, THHN ENCLOSED IN ½"(MIN) E.M.T. PER NATIONAL ELECTRIC CODE. FITTINGS, FIXTURES, AND DEVICES ARE U.L. LABELED. ALL WIRING TO TERMINATE AT C.B. PANEL. ALL CIRCUITS HAVE GREEN GROUND WIRE.
- D. BOOTH WILL HAVE A 3" CANOPY OVERHANG ON ALL SIDES.
- E. LIFTING RING(S) ARE PROVIDED ON ROOF.
- F. NO ON SITE WORK BY PAR-KUT.

GENERAL NOTES

PAINT COLOR:
(PLEASE SPECIFY COLOR)

NOTE: THIS PRINT AND DESIGN ARE THE PROPERTY OF PAR-KUT INTERNATIONAL, INC. IT MUST NOT BE REPRODUCED IN ANY MANNER, NOR SHALL IT BE SUBMITTED TO OUTSIDE PARTIES FOR EXAMINATION WITHOUT OUR CONSENT. IT SHALL BE USED ONLY AS A MEANS OF REFERENCE TO WORK DESIGNED AND FURNISHED BY PAR-KUT. PAR-KUT RESERVES THE RIGHT TO MAKE CHANGES TO DESIGN FOR ENGINEERING PURPOSES WITHOUT NOTICE. REVISIONS MAY NOT BE NOTED.

PAR-KUT INTERNATIONAL, INC.
40961 Production Drive
Harrison Twp, Mich.
48045-1351
Ph. (586) 468-2947
www.parkut.com



DWG# pk125 SHEET A-1

STANDARD 5' X 12' BOOTH
MODEL 125

PO#		DRAWN BY		REVISED	
SCALE	NTS	JJD		11-5-2014	
DATE	7-13-2010	SIZE	5' X 12'	QTY	
CHK'D BY:		SALES REPRESENTATIVE			